

# DOOR KING SYSTEMS

access control solutions™

---

## PREVENTATIVE MAINTENANCE GUIDE GATE OPERATOR SYSTEMS

---

### INTRODUCTION:

- DoorKing Information

### GATE SAFETY:

- Entrapment Protection Requirements
- Resetting an Alarm Condition

### GATE OPERATORS:

- General Guidelines
  - Preventative Maintenance and Adjustments
    - ✓ Swing Gate Operators
    - ✓ Slide Gate Operators
    - ✓ Parking Gate Operators
    - ✓ Loop Detectors
-



**INTRODUCTION:** DoorKing is family owned and operated, providing quality products since 1948. We maintain careful control of all aspects in the design and manufacturing of our systems. All engineering and design work is performed at our main facility in California. We also manufacture our electronic control circuit boards, and manufacture all of our Vehicular Gate Operators and Telephone Entry Systems at this facility.

DoorKing products are available through our network of Dealers and Distributors. We provide factory training programs, and regional training seminars to help our Dealers keep up to date on products and technical information. In addition to our Dealers and Distributors, DoorKing has several regional offices to help provide local contact for our valued clients:

### **DoorKing East**

Ed Curry  
Vineland, NJ  
Ph: 858-691-1100  
Fx: 856-691-0001

### **DoorKing South**

Dave Minner, George Hendrix  
Woodstock, GA  
Ph: 770-926-1526  
Fx: 770-926-1594

### **DoorKing Southeast**

Chuck Fink  
Sebring, FL  
Ph: 863-471-9339  
Fx: 863-471-3837

### **DoorKing North**

Larry Wanat  
Elgin, IL  
Ph: 847-888-4810  
Fx: 847-888-4820

### **DoorKing Central**

Jeff Marshall  
Plano, TX  
Ph: 972-612-4842  
Fx: 972-612-0803

### **DoorKing West**

Lamar Jackson  
Cameron Park, CA  
Ph: 530-676-8941  
Fx: 530-676-9824

### **DoorKing Northwest**

Dan Morris  
Seattle, WA  
Ph: 206-525-5595  
Fx: 206-525-5704

### **DoorKing Southwest**

Jac Whitmire  
Phoenix, AZ  
Ph: 480-413-2010  
Fx: 480-413-2001

### **DoorKing So Central**

Tony Thornton  
Pearl, MS  
Ph: 601-664-1199  
Fx: 601-664-1193

DoorKing has also developed a Training Program for Property Management companies. This is designed to teach maintenance personnel how to properly maintain their DoorKing systems. The information provided will assist in the following areas:

- ✓ Institute a Preventative Maintenance program for DoorKing systems.
- ✓ Provide periodic maintenance and adjustment on DoorKing systems to help ensure safe and proper operation
- ✓ Educate maintenance personnel on how these systems should operate under normal conditions, and how they react under Alarm or Entrapment conditions, Power Outage conditions, etc.
- ✓ Instruct maintenance personnel on how to reset the system should an alarm or shutdown condition exist.
- ✓ Instruct maintenance personnel on what to look for when the gate system experiences operational problems. This can help the Service Dealer when they are repairing the gate system.

This Preventative Maintenance Guide includes maintenance schedules for various models of DoorKing Gate Operators. These should be posted in the shop area and a program should be established to ensure that proper maintenance is performed on the Gate Operator System.



## GATE OPERATOR SAFETY AND ENTRAPMENT PROTECTION

*Compromising on gate and gate operator safety can have tragic results. By Rick Sedivy (excerpt from article dated Dec, 1996)*

A few years ago, in Illinois, a six year old child was pinned by a slide gate at an apartment complex and was suffocated.

According to the police, the accident occurred when a resident activated the gate to open with a remote control device. As the gate began to run open, two children jumped on the gate. The resident screamed for the children to get off. One child jumped off, but the other was pinned between the gate and the fence post. A police officer stated that the gate had a safety device, but it only worked during the closing cycle.

In California, a young girl was going to a friend's house to babysit. She reached through the gate to activate a switch on the inside. When the gate started, she was pulled into the gate pocket and suffocated.

In Houston, an adult male reached through a gate to activate a digital keypad. His employer conveniently had a hole cut through the gate just

so his employees could do this if they were on the outside of the gate. When the gentleman entered the digital code, the gate started and pulled him into the gate pocket. The gentleman died of asphyxiation.

The incidents described here (unfortunately, there are more) disprove many outdated schools of thought regarding gates and gate operator safety. To begin, automated gates are just as dangerous, and in fact maybe more dangerous because of entrapment possibilities, in the opening cycle as they are in the closing cycle. For years, manufacturers and installers addressed only safety concerns when the gate was in the closing cycle. Reversing edges are often installed on the leading edge of a slide gate, giving everyone a false sense of safety, and many manufacturers made no provisions whatsoever to sense gate obstructions in the opening cycle. The fact is people are being injured and killed by slide gates running in the OPEN direction.

Gate Operating systems can be made safe, but achieving this safety requires the cooperation of the

manufacturer, the installer and the End User!

### GATE WARNING SIGNS

Gate Warning Signs are included with all DoorKing vehicular gate operators. This sign is a requirement for compliance with the UL 325 Standard for Gate Safety. The sign must be posted so that people approaching the gate, from inside or outside, can clearly view and read the sign.



## PEDESTRIAN GATES ARE IMPORTANT

One of the hazards of automated vehicular gates is that everyone seems to want to use the vehicular gate and traffic lane as a pedestrian walk way. This creates two hazards. First, pedestrians are in the traffic lane competing with vehicles. Second, automated gate operators are not designed for use in pedestrian traffic applications.

DoorKing does not manufacture any operator designed for pedestrian traffic control and our operators must never be used in this type of application. There are

companies that design products specifically for this type of use

A requirement for compliance with the UL 325 Standard for Gate Safety, a separate pedestrian entrance must be provided whenever a Vehicular Gate is Automated. This must be separate from the traffic lane and provide entry for pedestrian traffic without utilizing the Vehicular Gates.

## GENERAL GATE OPERATOR SYSTEM GUIDELINES DEFINING THE PROBLEM

**Should a problem occur with the gate system, before turning off power to the operator, Inspect the system** - Gate Operator failures are often intermittent and difficult for the service dealer to trouble shoot. By inspecting the gate operator and **looking at the indicator lights on the circuit board**, you can help reduce the amount of time needed to repair the gate system.

**Before resetting the system try to observe the gate failure** - In many cases, the gate system may have an intermittent problem. These often can be reset by cycling the power OFF then ON, putting the gate back into operation. However, the intermittent problem may still exist. Try to observe the problem and make a note on what you see during the gate failure prior to resetting the operator..

**Give the system a visual inspection** - Many common problems are the result of physical factors of the installation.

- Keep the area free of debris (mud, rocks, leaves, etc.). Make sure that no branches, or bushes are interfering with the gate travel.
- See if the gate will move freely by hand.
- Make sure the system is properly grounded.

**Keep Iron in good repair** - If the gate has been hit it can be out of alignment and can result in operational problems with the gate system. **Make sure that all Standard maintenance is performed on the operators**, Proper lubrication for wheels, rollers, hinge bearings, chains, etc. Proper adjustment on drive chain (min. 1" of sag per 10' of gate length). **Test all Entrapment Protection devices on a regular basis. Do Not Compensate for a in disrepair by tightening down the clutch or reducing gate reverse sensitivities.**

**Keep a Log of Gate Problems or failures** - A time consuming part of servicing a Gate System is tracking down the problem. Try to keep a log of gate problems, and of what steps you have taken to reset the gate system. If a service call is required, this can help the Service Technician in trouble shooting the source of the problem.

## GATE INSTALLATION

The physical installation and wiring of the operator is a critical factor in reliable gate operation. When servicing a gate system, double check some of the installation factors to see if they may be the source of the problem.

- **Location of the Operator** - SLIDE GATE OPERATORS should be located within a couple of inches of the gate, with the concrete pad beneath the entire operator. Do not hang the back edge of the operator over the pad. Also, make sure the operator is mounted square to the gate and that the chain runs straight through the operator.  
SWING GATE OPERATORS must be located to provide proper arm geometry and smooth gate movement. The Arms should rotate 180° when running from the Closed to the Open position.
- **Mounting the Operator** - Make sure that the operator is securely mounted to the concrete pad. There should be no movement of the operator on its mounts.
- **UL 325 related Devices** - Proper installation of all related Entrapment Protection Devices will significantly improve the gate system reliability. This includes any Reversing Edges on the gate and all Photo Cell devices. Test all devices for proper operation.

## TRACKING DOWN THE PROBLEM

Many gate system operational problems or failures can be difficult to track down. It is sometimes helpful to isolate what area is causing the actual problem. With the new UL 325 requirements, Gate Operators may also enter a “Shutdown” condition if the operator senses an obstruction. Please keep in mind how Gate Operators will function and react due to the new UL 325 requirements:

**UL 325 Related Functions** - The updated UL 325 related functions affect how the gate operates. These may result in a gate not responding to open or close commands, getting “Stuck” in the Open or Closed position, or reversing during operation. Remember the following gate conditions:

- ✓ **Photo Cells**, if connected to the UL terminals will Stop the Gate, not reverse the gate.
- ✓ **Soft Shutdown** - If the gate senses an obstruction in either direction, it will reverse and return to the Limit Position. If the gate is closing, it will reverse and return to the full open position. **IT WILL NOT TIME OUT AND CLOSE.** It will Hold at the OPEN position until an open command has been given to the gate (Loop, Remote, Keypad, etc.)
- ✓ If the gate senses an obstruction, reverses and senses a 2<sup>nd</sup> obstruction, it will stop and enter an Alarm or Hard Shutdown condition. **The gate will not function** until the gate is reset. All access devices will be disabled, including the Phone Entry system, RF Control, Card Readers, Keypads, etc. An Alarm Tone will sound for 5 minutes following a shutdown. After 5 minutes, the Alarm Tone will beep every 5 seconds, indicating that the operator is in a Hard Shutdown condition. **Activate the Alarm Reset button (by Power Switch) or cycle power OFF / ON to reset gate system.**

On the following pages we provide some simple troubleshooting tips and common adjustments that can help maintain proper operation for your system. When working on the system, keep notes on what steps you have taken and what problems you observed. This will help the Service Technician repair your system, should a service call be required.

### 9000 Series Slide Gate Operators:

- ◆ Model 9050 1/2 HP Limited Duty Residential operator
- ◆ Model 9070 1/2 HP Light Duty Residential / Light Commercial Operator.



### 9100 Series Operators

- ◆ Model 9100 1/2 HP Continuous Duty Commercial operator
- ◆ Model 9150 1/2 & 1 HP Continuous Duty Commercial / Industrial Operator.



### 9310 Series Operators

- ◆ Advanced Limit Switch Design
- ◆ Model 9310 1/2 & 1 HP Continuous Duty Commercial operator



### Model 9200 1hp models Industrial Op w/ limit switch design

- ◆ Continuous Duty Operation.
- ◆ 115, 230 vac single phase
- ◆ 208, 230 or 460 vac 3-phase

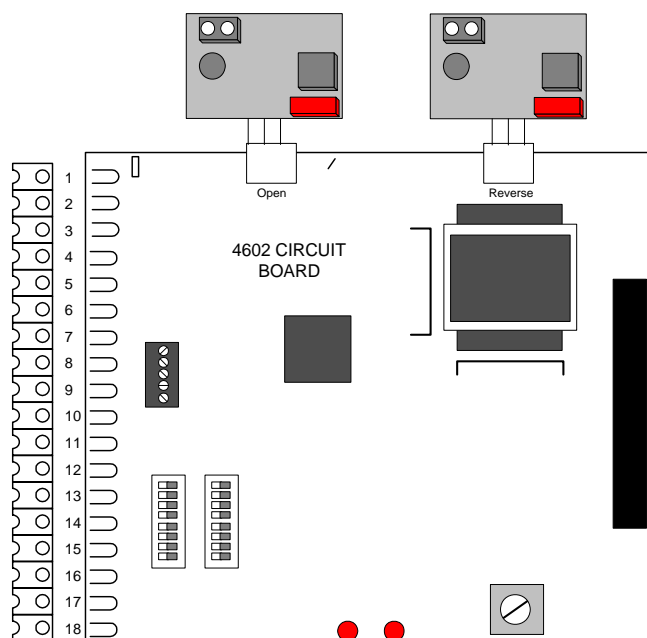

Gate Operator Control Board (typical)

## IMPORTANT NOTICES

Vehicular gate systems provide convenience to their users and limit vehicular traffic onto your property. These systems can produce high levels of force; therefore it is important that you are aware of possible hazards associated with your gate operating system. These hazards may include pinch points, entrapment, absence of controlled pedestrian access or traffic backup.

Be sure that the installer has instructed you on the proper operation of the gate and gate operator system. Be sure that the installer has trained you about the basic functions of the required reversing systems associated with your gate operating system and how to test them. These include reversing loops, inherent reversing system, electric edges, photoelectric cells, or other external devices.

- This Owner's Manual is your property. Keep it in a safe place for future reference.
- Loops and loop detectors must be installed with this gate operator to prevent the gate from closing on vehicular traffic.
- The speed limit for vehicular traffic through the gate area is **5 MPH**. Install speed bumps and signs to keep vehicular traffic from speeding through the gate area. Failure to adhere to posted speed limits can result in damage to the gate, gate operator, and to the vehicle.
- Be sure that all residents are familiar with the proper use of the gate and gate operator. Be sure that all residents are familiar with the possible hazards associated with the gate system.
- Be sure that all warning signs are permanently installed on both sides of the gate in an area where they are fully visible to traffic.
- It is your responsibility to periodically check all reversing devices. If any of these devices are observed to function improperly, remove the operator from service immediately and contact your installing or servicing dealer.
- Follow the recommended maintenance schedule.
- Do not allow children to play in the area of the operator or to play with any gate-operating device.
- Be sure that all activating devices are installed a minimum distance of 10 feet away from the gate and gate operator, or in such a way that a person cannot touch the gate or gate operator while using the activating device. If activating devices are installed in violation of these restrictions, immediately remove the gate operator from service and contact your installing dealer.
- To remove the gate operator from service, operate the gate to the full open position and then shut off power to the operator at the service panel.

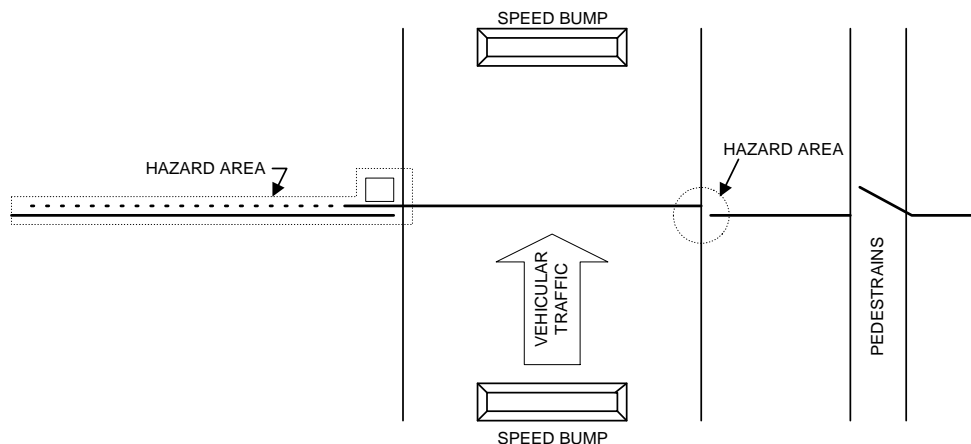



## IMPORTANT SAFETY INSTRUCTIONS

**WARNING - To reduce the risk of injury or death:**

1. READ AND FOLLOW ALL INSTRUCTIONS.
2. Never let children operate or play with gate controls. Keep the remote control away from children.
3. Always keep people and objects away from gate. NO ONE SHOULD CROSS THE PATH OF THE MOVING GATE.
4. Test the operator monthly. The gate MUST reverse on contact with a rigid object or stop or reverse when an object activates the non-contact sensors. After adjusting the force or the limit of travel, retest the gate operator. Failure to adjust and retest the gate operator properly can increase the risk of injury or death.
5. KEEP GATES PROPERLY MAINTAINED. Read the owner's manual. Have a qualified service person make repairs to gate hardware.
6. The entrance is for vehicles only. Pedestrians must use separate entrance.
7. SAVE THESE INSTRUCTIONS!

### 4.1 POWER AND RESET SWITCHES

Open the power switch cover located on the side of the operator to access the MAIN POWER, BACKUP POWER and the operator RESET switches (Figure 38).

- The RESET switch is used to turn off the entrapment alarm and to reset the operator after a hard shutdown has occurred.
- The AC POWER toggle switch turns power to the operator ON (toggle up) or OFF (toggle down).
- The DC POWER toggle switch turns the DC backup system power ON (toggle up) or OFF (toggle down). This switch is only installed on model 6100 operators with the DC backup system installed.

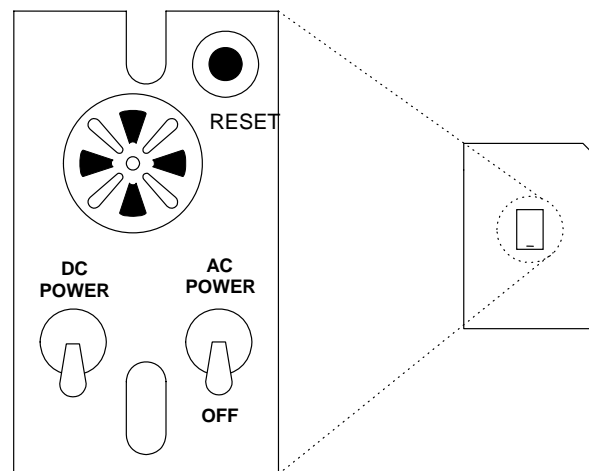
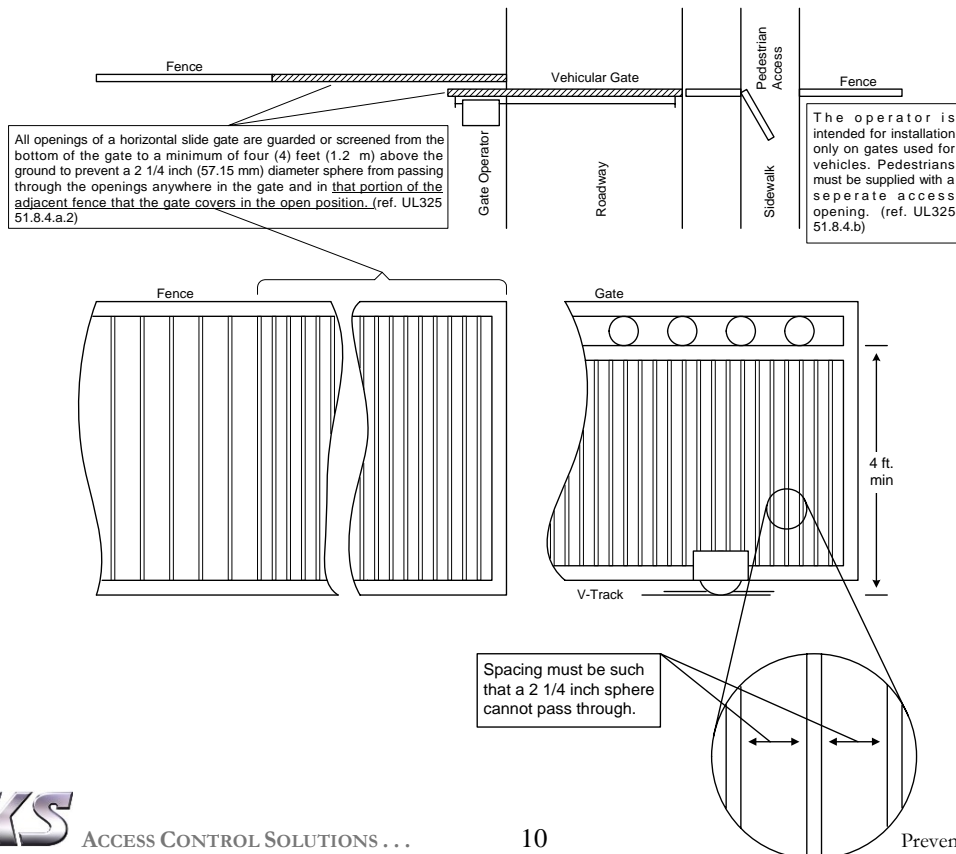

Figure 38

**RESTRICTIONS AND WARNINGS**

*Install The Gate Operator Only If:*

- The operator is appropriate for the usage Class of the application and the gate is within the weight and length limitations specified for the operator.
- All openings of a horizontal slide gate are guarded or screened from the bottom of the gate to a minimum of 4 feet (1.2 m) above the ground to prevent a 2 ¼ inch (57.15 mm) diameter sphere from passing through the openings anywhere in the gate, and in that portion of the adjacent fence that the gate covers in the open position.
- All exposed pinch points are eliminated or guarded.
- This operator is intended for installation only on slide gates used to control vehicular traffic. Pedestrians must be provided with a separate access opening.
- The gate must be installed in a location so that sufficient clearance is provided between the gate and adjacent structures when opening and closing to reduce the risk of entrapment (see diagram). Sliding gates should not open into public access areas.
- The gate must be properly installed and work freely in both directions prior to the installation of the gate operator. Do not over-tighten the operator clutch to compensate for a damaged gate.
- Controls must be far enough from the gate so that the user is prevented from coming in contact with the gate while operating the controls. Outdoor or easily accessible controls should have a security feature to prevent unauthorized use.
- All warning signs and placards must be installed where visible in the area of the gate.



## MAINTENANCE

Inspection and service of this gate operator by a qualified technician should be performed anytime a malfunction is observed or suspected. High cycle usage may require more frequent service checks.

When servicing the gate operator, always check any secondary (external) reversing devices (loops, photo eyes, etc.) for proper operation. If external reversing devices cannot be made operable, do not place this operator in service until the malfunction can be identified and corrected.

**Always check the inherent reversing system when performing any maintenance. If the inherent reversing system cannot be made operable, remove this operator from service until the cause of the malfunction is identified and corrected. Keeping this operator in service when the inherent reversing system is malfunctioning creates a hazard for persons which can result in serious injury or death should they become entrapped in the gate.**

When servicing this gate operator, always turn power **OFF!!**

MAINTENANCE SCHEDULE		MONTHLY INTERVAL		
		3	6	12
Alarm	Activate the primary (inherent) reverse system by blocking the gate with a solid object. When the gate reverses, block the gate in the opposite direction prior to the limit being reached. The entrapment alarm should activate. Press the reset button to silence the alarm.	✓		
Drive Belt	Check for alignment, tightness and wear.		✓	
Chain	Check for sagging. Tighten if necessary.		✓	
Clutch	Check for proper slippage when an obstruction is encountered.	✓		
Fire Dept.	Check emergency vehicle access device for proper operation.	✓		
Gate	Inspect for damage. Check gate wheels, rollers and guides for wear and grease if necessary.		✓	
Grease	Wheels and guide rollers if necessary.		✓	
Loop(s)	Check vehicular reverse and shadow loops for proper operation.	✓		
Primary Reverse System	Check that the gate reverses on contact with an object in both the opening and closing cycles. Adjust the clutch if necessary.	✓		
Pulleys	Check for alignment. Check setscrews.		✓	
Release	Check manual release for proper operation.	✓		
Secondary Reverse Device	Check that secondary (external) reverse device(s) stop or reverse the gate when activated.	✓		
Complete	Complete check of gate and gate operating system.			✓

## TROUBLE SHOOTING - DOOR KING SLIDE GATE OPERATORS, MODEL 9100 & 9150

---

<u>Symptom</u>	<u>Items to check</u>
Operator will not run	<ol style="list-style-type: none"><li>1. Be sure AC power switch is on.</li><li>2. Check if Power LED on circuit board is on, (<i>indicates power to control board.</i>)</li></ol>
Operator will not run Power LED is ON	<ol style="list-style-type: none"><li>1. Activate Card Reader, Transmitter or Phone Entry. Look at circuit board inside Gate Operator and see if LED's on the "Keyswitch" or "Full Open" terminals light up when device is activated. (<i>indicates that the board is receiving open command.</i>)</li><li>2. Be sure the chain is not too tight. This may cause the operator to stall. Chain should have approximately 1" of slack per 10' of gate length.</li></ol>
Gate opens short distance, then stops and reverses.	<ol style="list-style-type: none"><li>1. Check if the how much force is needed to stop the gate. It should take around 40 pounds of force to stop gate. If the gate can be stopped by less pressure the clutch or reverse sensitivity may need adjustment. (See Following Page)</li><li>2. Check that the chain is not too tight.</li><li>3. While gate is moving, check that the counter LED sensors are blinking (<b>Slide Gate:</b> <i>bottom center of board, above shaft</i>).</li><li>4. Turn power off manually roll gate open and closed to check if there is any binding point, the gate should roll freely throughout travel.</li></ol>
Gate opens but will not close.	<ol style="list-style-type: none"><li>1. Check if circuit board LED's on terminals 2, 4, 5 or 6 are on. An input on any of these terminals will hold gate open.</li><li>2. Check red LED on Reverse and/or Exit Loop Detectors. If on then loop is holding gate open. Also check Photo Eye devices.</li></ol>
Gate starts to close then reverses to open.	<ol style="list-style-type: none"><li>1. Check for binding of gate at point of reverse.</li><li>2. Check if the how much force is needed to stop the gate.</li><li>3. Check counter LED's</li><li>4. Check Loop Detector LED's to see if loop is sensing the gate.</li></ol>
Loop Detector LED is on continuously.	<ol style="list-style-type: none"><li>1. Activate reset switch on loop detector (for DoorKing Model 9405, 9406 detectors this is a small push button next to the large bank of dip switches. To reset press reset button.</li></ol>

### TROUBLE SHOOTING HINTS

If a malfunction occurs, isolate the problem to one of three areas: The Operator, The Keying Devices (card reader, phone entry, etc.) or the Loop Detectors.

When placing a service call to the Authorized Dealer, relate what you found when following the above steps.

**CHAIN ADJUSTMENT**

1. Secure the chain brackets to each end of the gate so that the brackets are level with the top chain knockouts in the operator housing. Brackets should be attached to the inside of the frame so that the chain bolts, when attached, do not protrude beyond the frame of the gate (figure 10).
2. Route the chain through the gate operator: over the chain guide idlers and under the drive sprocket (figure 12).
3. Slide each end of the chain through a chain stop (optional). Chain stops are not required if the gate has physical stops.
4. Attach the chain to the chain bolts using the master links supplied, and then attach the chain bolts to the chain brackets using the hardware supplied (figure 10). Make any adjustments to the chain length at this time.
5. Adjust the chain bolts to tighten the chain. The chain should sag a minimum of one (1) inch per 10 feet of travel. Do not over tighten the chain. **IMPORTANT!! Be sure that the chain is parallel to the gate (figure 11). Installing the chain in any other manner will cause excessive noise, chain idler wear and chain stretching.**
6. Manually open the gate to the full open position and secure the chain stop (if installed) to the chain so that it is in contact with the operator housing.
7. Manually close the gate to the full closed position and secure the chain stop (if installed) to the chain so that it is in contact with the operator housing.

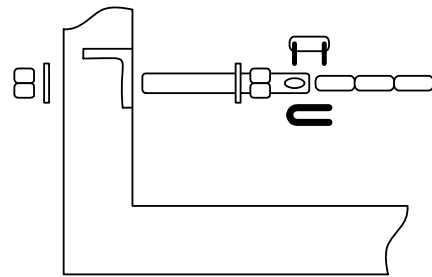

Figure 1

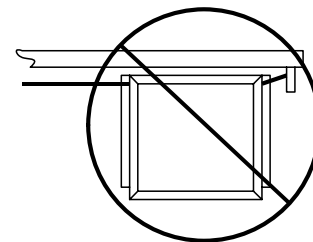
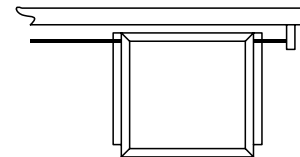
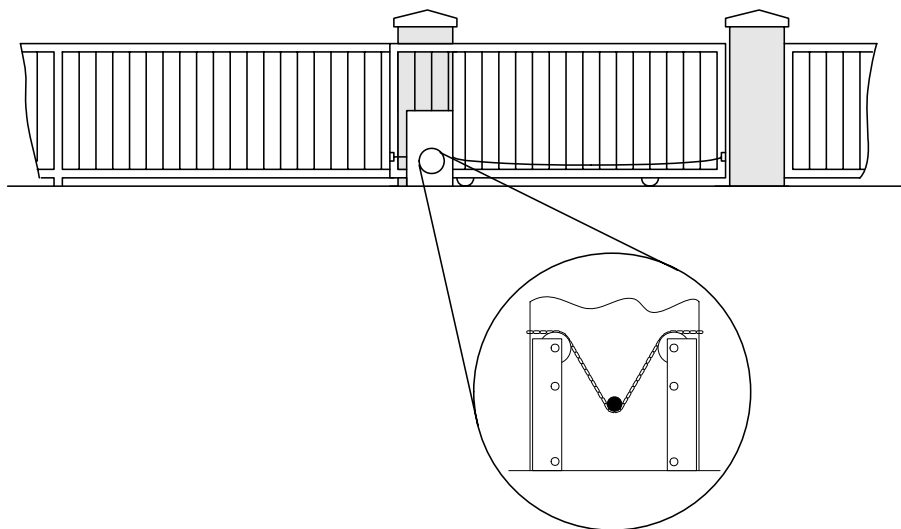

Figure 2



### Operator Adjustments

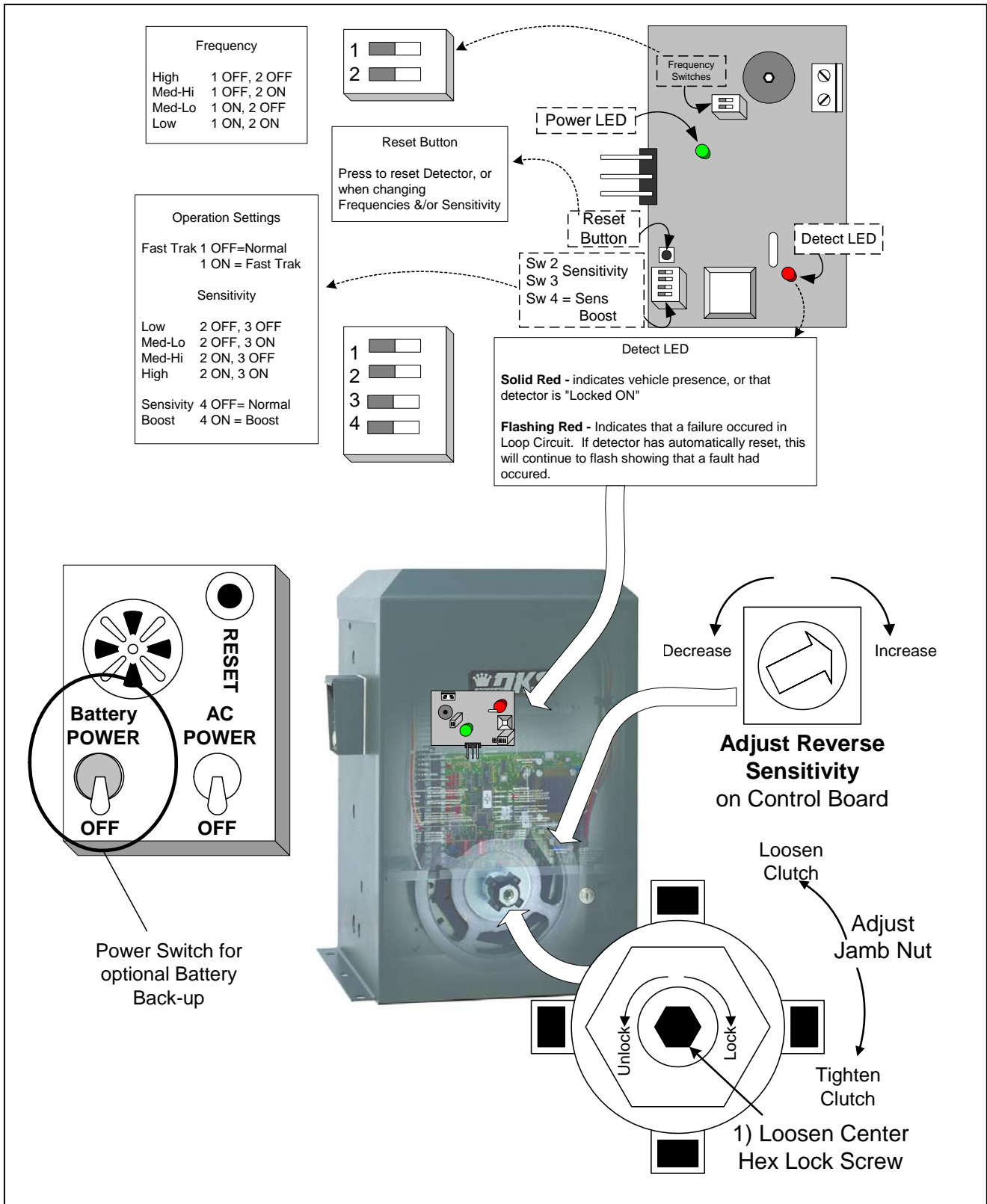

Figure 3

## 3.4 INHERENT REVERSE ADJUSTMENT

This vehicular gate operator is equipped with an inherent (Type A) entrapment sensing system. This system will sense an obstruction in either the opening or closing gate cycles and will cause the gate to reverse direction should an obstruction be encountered. For this system to function correctly, the gate must be properly installed and work freely in both directions. A good set of ball bearing wheels (or rollers) is essential for proper slide gate operation.

### 3.4.1 REVERSE SENSITIVITY ADJUSTMENT

1. Make sure that the Automatic Limit setting has been completed (the gate has run at least 2 cycles since power was last turned ON)
2. Activate the gate operator by momentarily shorting terminal 4 and 18 with a 1-foot piece of 18 AWG wire.
3. While the gate is running, slowly rotate the reverse sensitivity potentiometer clockwise until the gate reverses travel, then back off 1/8 turn counter clockwise. (Rotating the sensitivity adjustment clockwise INCREASES the reverse sensitivity. Rotating this adjustment counter-clockwise DECREASES the reverse sensitivity.) NOTE: After the gate has reversed, the operator will assume a "soft shutdown" making it necessary to initiate the cycle again by momentarily shorting across terminals 4 and 18 as in step 1.
4. Operate the gate a few times to be sure that it cycles completely.
5. Test the gate in both the Opening and Closing cycles. Place an immobile object along the path of the gate so that the gate will strike it while the gate is in motion. The gate must reverse direction after striking the object. If it does not, increase the reverse sensitivity by turning the potentiometer 1/8 turn clockwise, then repeat this test.
6. You may have to repeat step 2 several times to find the correct sensitivity adjustment.

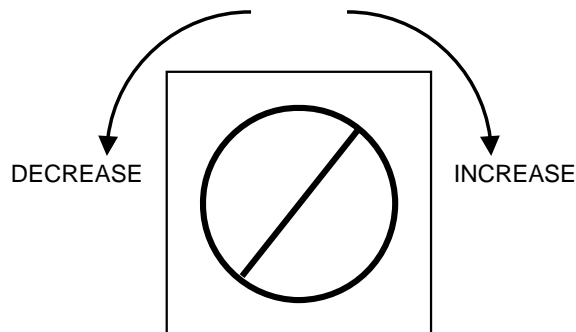

Figure 4

### 3.4.2 CLUTCH ADJUSTMENT

In addition to the reverse sensitivity adjustment, this operator is equipped with a mechanical slip clutch to further reduce the possibility of injury should an entrapment occur. Do not over tighten the clutch in this gate operator to compensate for a damaged or poorly constructed gate, or to compensate for a gate that is too heavy or that has damaged wheels or rollers. Doing this can create a hazard which can result in serious injury or death to persons who may become entrapped.

1. **Be sure power to the operator is turned OFF whenever adjustments to the clutch are made.** Loosen the center lock screw in the center of the adjustment nut. (This is either an allen set screw or a large bolt), and then loosen the jamb nut. You may have to hold the large pulley to loosen this nut.
2. Tighten the jamb nut so that it is finger tight, and then tighten it one complete turn with a wrench. Tighten the center hex lock screw to lock the jamb nut in place.
3. Apply power to the gate operator and cycle it to allow the operator to adjust its limit settings as described in section 3.3.
4. Activate the gate operator by momentarily shorting across terminals 4 and 18 with a 1-foot 18 AWG wire. When the gate begins to open, determine if the clutch is slipping. If the clutch is slipping, turn power OFF and tighten the jamb nut one more turn as described in step 2, then repeat steps 3 and 4 (This process may have to be repeated several times to get the right clutch adjustment).
5. After adjusting the clutch so that the gate opens and closes without it slipping, place an immobile object along the path of the gate so that the gate will strike it while in the open cycle. The clutch should slip and the gate must reverse direction after striking the object. If it does not, repeat steps 1-3 and 5 to readjust the clutch. **NOTE:** After the gate has reversed, the operator will assume a "soft shutdown" making it necessary to initiate the cycle again by momentarily shorting across terminals 4 and 18.
6. Place an immobile object along the path of the gate so that the gate will strike it while in the close cycle. The gate must reverse direction after striking the object. If it does not, repeat steps 1-3 and 6 to readjust the clutch. **NOTE:** After the gate has reversed, the operator will assume a "soft shutdown" making it necessary to initiate the cycle again by momentarily shorting across terminals 4 and 18 to initiate the auto close timer.
7. The ideal clutch adjustment will allow the operator to move the gate through its entire travel cycle without slipping, but will slip upon contact with an obstruction with no more than 75 Lbs of force. This force can be measured with a gate scale, DoorKing P/N 2600-225.

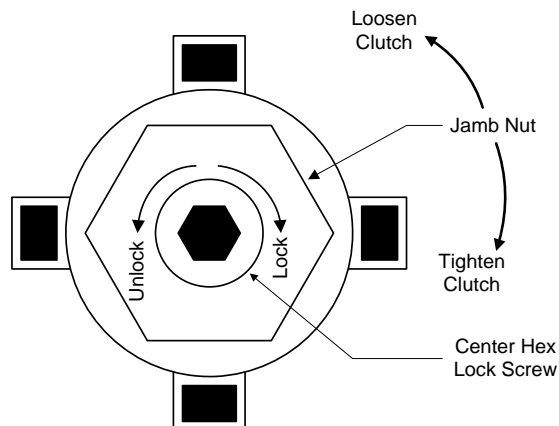

Figure 5





## LOOP DETECTION SYSTEMS

### Loop Layouts and Operation:

**Exit Loop** - Opens gate when vehicle is present. Typically utilized for “Free Exit” applications.

**Reverse Loop (optional Stop Loop)** - Will hold gate open when vehicle is present. After vehicle departs, gate will time out and run closed. During Closing Cycle, a Vehicle activating this loop will Reverse and re-open the gate. As an option on Slide gates, these loops may be set to Stop the gate rather than re-open them (see Advanced Systems section).

Typically, 2 reverse loops may be connected to 1 Loop Detector.

**Shadow Loop** - Functions like a Reverse Loop, but only active when gate is at the Full Open position. Will hold gate open while vehicle is present. Once gate starts its closing cycle, this loop is disabled.

**Down Loop** - Used with Parking Gate Operators. Will hold arm UP while vehicle is present. Once vehicle clears loop, Arm will Lower to DOWN position.

**Arming Loop** - This is tied into Card Reader or other type of Access Device. Reader Device will only function while vehicle is present.

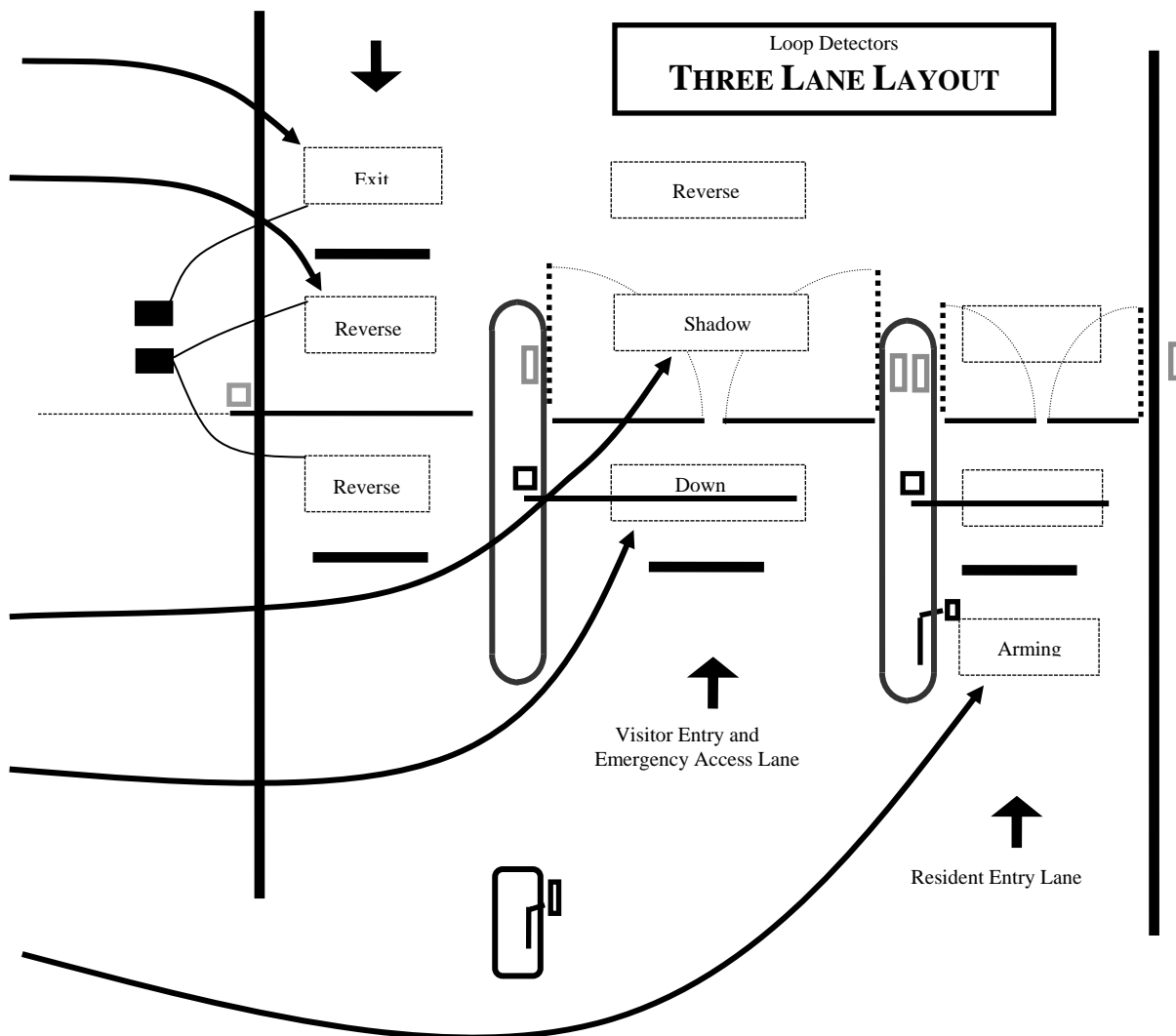

## TESTING LOOP DETECTION SYSTEMS

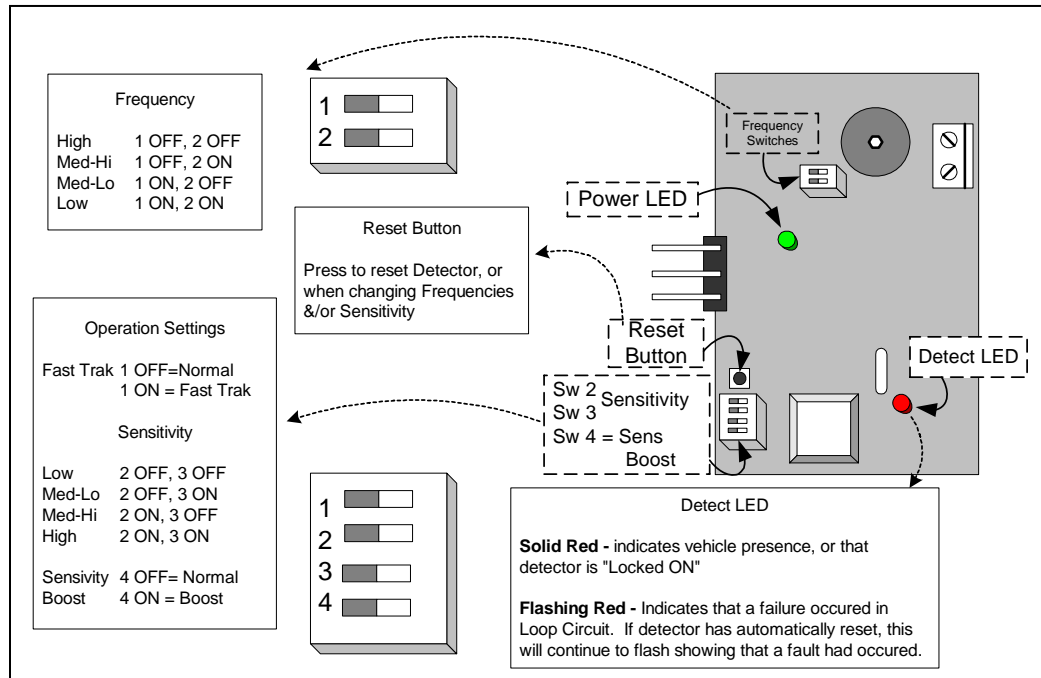

### Detector Adjustments:

**Frequency:** Separate each loop to avoid CrossTalk

**Sensitivity:** How much change is needed in Loop Field to detect. Can affect height of detection.

**Boost:** automatically boosts to an extremely high sensitivity upon detection. When vehicle leaves loop, sensitivity drops back to original setting.

**Fast Trak: USE WITH CAUTION!** This will help detector adjust as loop tuning drifts. *This also will lower Hold Time if a car parks over the loop*

**LED:** Red for Detect. Flash count on start-up to show frequency. Continuous blink indicates Loop Fault occurred. Will continue till reset.

# DOOR KING 9100 & 9150 SLIDE GATE OPERATORS

## Typical Block Wiring Diagram

**UL 325 Standard for Safety:**  
 Secondary Entrapment Protection Devices:  
 ✓ Open Cycle Photo Cell  
 ✓ Close Cycle Photo Cell  
 ✓ Open Cycle Contact Sensor Edge  
 ✓ Close Cycle Contact Sensor Edge  
 ✓ Common

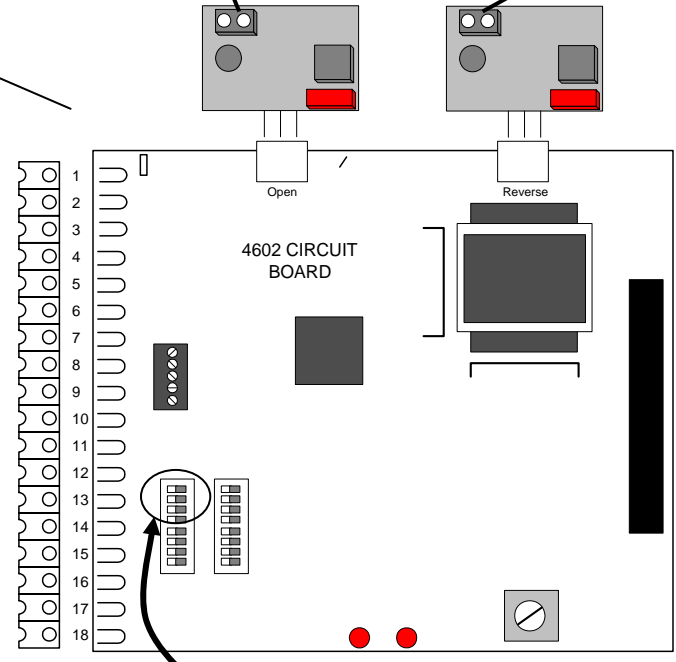
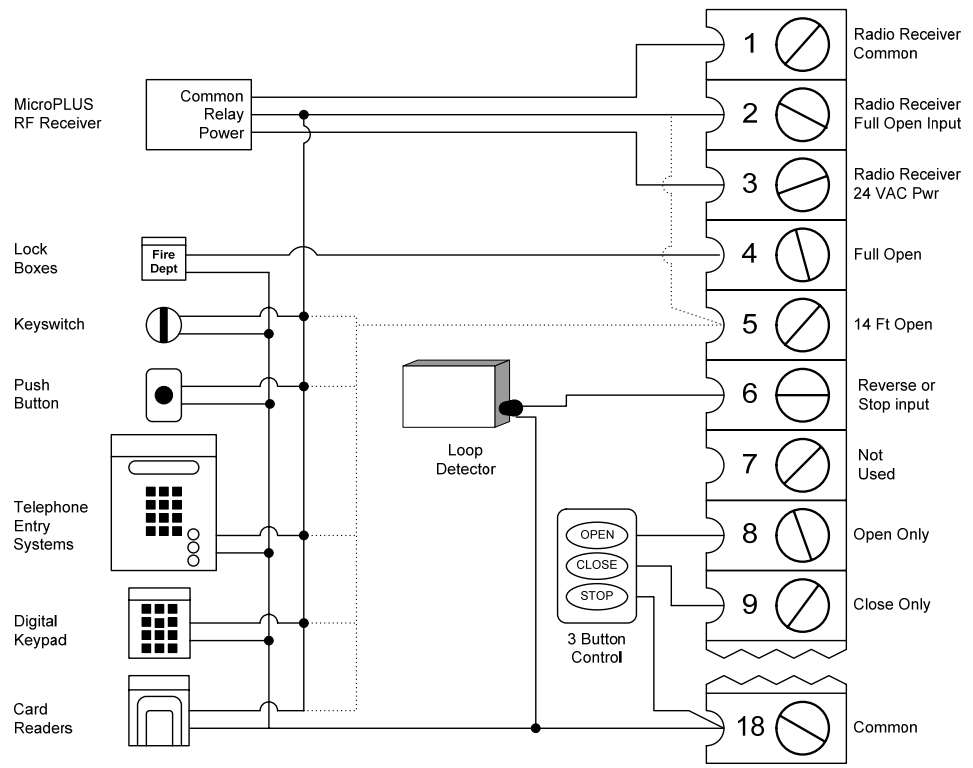

**Programming Switches**  
 Sw 1 = Direction  
 Sw 2 = Timer OFF/ON

# DOORKING SLIDE GATE OPERATORS

## LED Indicator Lights

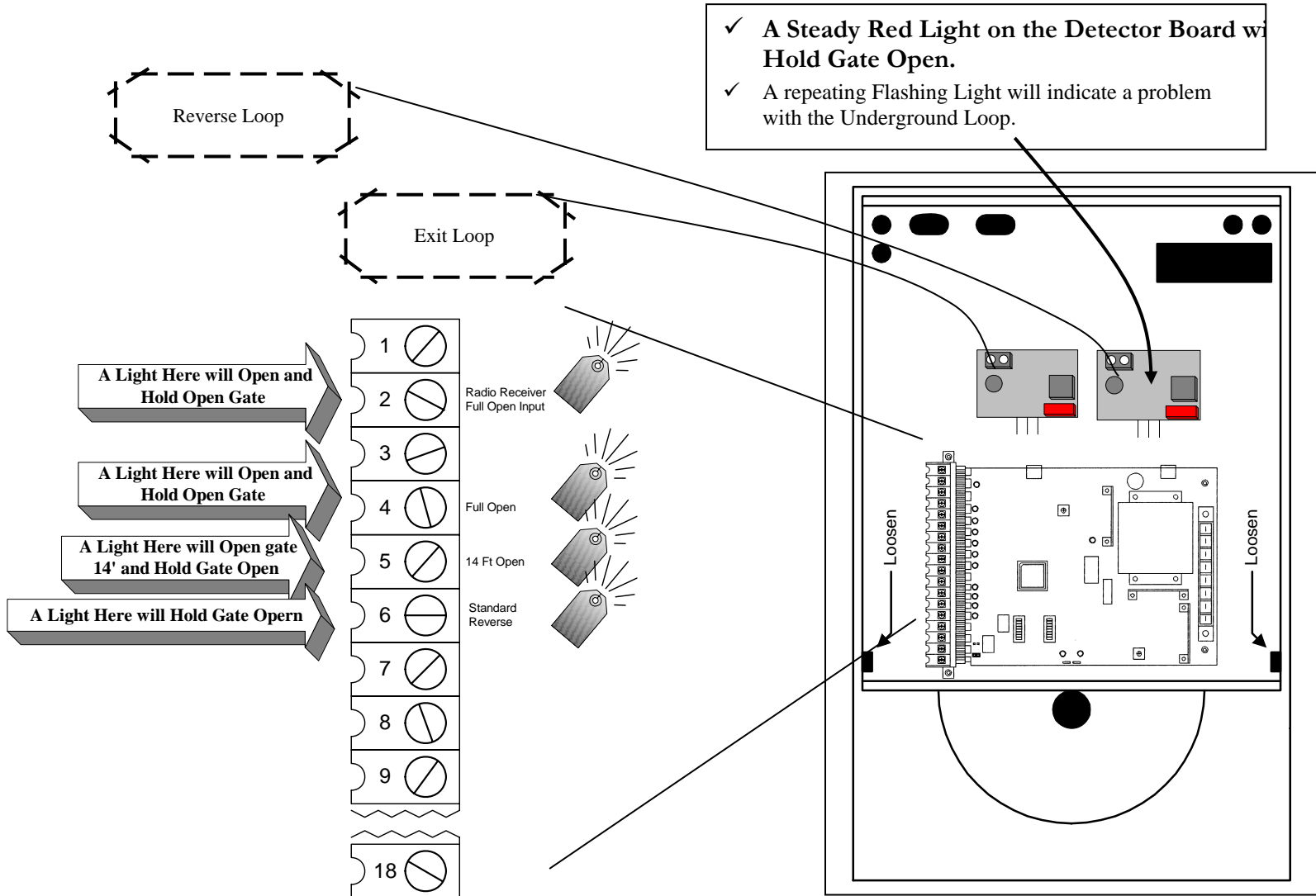

# **TROUBLESHOOTING - DOORKING SWING GATE OPERATORS**

---

## **Model 6100 1/2 hp Commercial Operator**

- ◆ Class I, II, III & IV.
- ◆ 14' Gate Length, 500lb. max gate wt.
- ◆ Bi-parting Master/Slave configuration available (single control board)
- ◆ Battery Back-up convenience drive option.

## **Model 6300 1/2 hp & 1hp models Commercial Op w/ advanced features**

- ◆ Class I, II, III & IV.
- ◆ 1/2hp - 18' Gate Length, 600lb. max gate wt.
- ◆ 1hp - 22' Gate length, 800lb. max gate wt.
- ◆ Bi-parting Master/Slave configuration available (single control board)
- ◆ Continuous Duty Operation.
- ◆ Battery Back-up Convenience Drive available.
- ◆ 115, 230 or 460 vac compatible (208 vac upon request)



# TROUBLESHOOTING - DOOR KING SWING GATE OPERATORS

## OPERATING INSTRUCTIONS

### IMPORTANT SAFETY INSTRUCTIONS

#### WARNING - To reduce the risk of injury or death:

1. READ AND FOLLOW ALL INSTRUCTIONS.
2. Never let children operate or play with gate controls. Keep the remote control away from children.
3. Always keep people and objects away from gate. NO ONE SHOULD CROSS THE PATH OF THE MOVING GATE.
4. Test the operator monthly. The gate MUST reverse on contact with a rigid object or stop or reverse when an object activates the non-contact sensors. After adjusting the force or the limit of travel, retest the gate operator. Failure to adjust and retest the gate operator properly can increase the risk of injury or death.
5. Use the emergency release only when the gate is not moving and power has been shut-off.
6. KEEP GATES PROPERLY MAINTAINED. Read the owner's manual. Have a qualified service person make repairs to gate hardware.
7. The entrance is for vehicles only. Pedestrians must use separate entrance.
8. SAVE THESE INSTRUCTIONS.

### 4.1 POWER AND RESET SWITCHES

Open the power switch cover located on the side of the operator to access the MAIN POWER, BACKUP POWER and the operator RESET switches (Figure 38).

- The RESET switch is used to turn off the entrapment alarm and to reset the operator after a hard shutdown has occurred.
- The AC POWER toggle switch turns power to the operator ON (toggle up) or OFF (toggle down).
- The DC POWER toggle switch turns the DC backup system power ON (toggle up) or OFF (toggle down). This switch is only installed on model 6100 operators with the DC backup system installed.

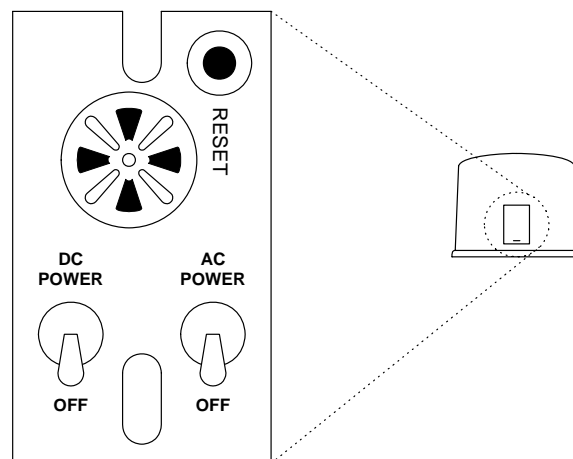

Figure 38

# TROUBLESHOOTING - DOOR KING SWING GATE OPERATORS

## MAINTENANCE

Inspection and service of this gate operator by a qualified technician should be performed anytime a malfunction is observed or suspected. High cycle usage may require more frequent service checks.

When servicing the gate operator, always check any secondary (external) reversing devices (loops, photo eyes, etc.) for proper operation. If external reversing devices cannot be made operable, do not place this operator in service until the malfunction can be identified and corrected.

**Always check the inherent reversing system when performing any maintenance. If the inherent reversing system cannot be made operable, remove this operator from service until the cause of the malfunction is identified and corrected. Keeping this operator in service when the inherent reversing system is malfunctioning creates a hazard for persons which can result in serious injury or death should they become entrapped in the gate.**

When servicing this gate operator, always turn power **OFF!!**

MAINTENANCE SCHEDULE		MONTHLY INTERVAL		
		3	6	12
Alarm	Activate the primary (inherent) reverse system by blocking the gate with a solid object. When the gate reverses, block the gate in the opposite direction prior to the limit being reached. The entrapment alarm should activate. Press the reset button to silence the alarm.	✓		
Arms	Check set screws and nuts. Check bushings for wear.		✓	
Backup System	If operator is equipped with option DC backup system, check to be sure the system opens the gate upon loss of AC power.	✓		
Batteries	If operator is equipped with optional DC backup system, check the batteries for any leakage or loose connections. Batteries should be replaced every two years.	✓		
Drive Belt	Check for alignment, tightness and wear.		✓	
Fire Dept.	Check emergency vehicle access device for proper operation.	✓		
Gate	Inspect for damage. Check gate hinges for wear and grease if necessary.		✓	
Gear	Inspect for wear. Grease if necessary. Use only EP Molybdenum Disulfide (Moly D) grease (DoorKing P/N 2600-770).		✓	
Grease	Main shaft zert fitting.		✓	
Primary Reverse System	Check that the gate reverses on contact with an object in both the opening and closing cycles. Adjust the clutch if necessary.	✓		
Loop(s)	Check vehicular reverse and shadow loops for proper operation.	✓		
Release	Check manual release for proper operation.	✓		
Secondary Reverse Device	Check secondary (external) reverse device(s) stop or reverse the gate when activated.	✓		
Worm Gear	Inspect for wear and proper alignment.		✓	
Complete	Complete check of gate and gate operating system.			✓



# TROUBLESHOOTING - DOOR KING SWING GATE OPERATORS

---

Symptom	Items to check
Operator will not run	<ol style="list-style-type: none"><li>1. Be sure AC power switch is on.</li><li>2. Check if Power LED on circuit board is on.</li></ol>
Operator will not run Power LED is ON	<ol style="list-style-type: none"><li>1. Activate Card Reader, Transmitter or Phone Entry. Look at circuit board inside Gate Operator and see if LED's on terminals 11 or 12 light up when device is activated.</li><li>2. Using a wire jumper, jump between terminals 11 &amp; 20, gate should open.</li></ol>
Gate opens short distance, then stops and reverses.	<ol style="list-style-type: none"><li>1. Check if the how much force is needed to stop the gate. It should take around 40 pounds of force to stop gate. If the gate can be stopped by less pressure the clutch may need adjustment. <b>(See Following Page)</b></li><li>2. While gate is moving, Check that the pulse counter LED sensor is blinking at terminal #9 (on bi-parting gates both counters must be blinking, terminals 9 &amp; 10).</li><li>3. Turn OFF power and unlock the manual release and check that the gate swings freely and that the hinges do not bind.</li></ol>
Gate opens but will not close.	<ol style="list-style-type: none"><li>1. Check if circuit board LED on terminals 11, 12 or 15 are on. If so, some device may be holding gate open.</li><li>2. Check red LED on Reverse and Exit Loop Detectors. If on then loop is holding gate open.</li></ol>
Gate starts to close then reverses to open.	<ol style="list-style-type: none"><li>1. Check for binding of gate at point of reverse.</li><li>2. Check if the how much force is needed to stop the gate.</li><li>3. Check counter LED's</li><li>4. Check Loop Detector LED's to see if loop is sensing the gate.</li></ol>
Loop Detector LED is on continuously.	<ol style="list-style-type: none"><li>1. Activate reset switch on loop detector (for DoorKing Model 9405, 9406 detectors this is a small push button next to the large bank of dip switches. To reset press reset button.</li></ol>

## TROUBLE SHOOTING HINTS

If a malfunction occurs, isolate the problem to one of three areas: The Operator, The Keying Devices (card reader, phone entry, etc.) or the Loop Detectors.

When placing a service call to the Authorized Dealer, relate what you found when following the above steps.

# TROUBLESHOOTING - DOORKING SWING GATE OPERATORS

## Operator Adjustments

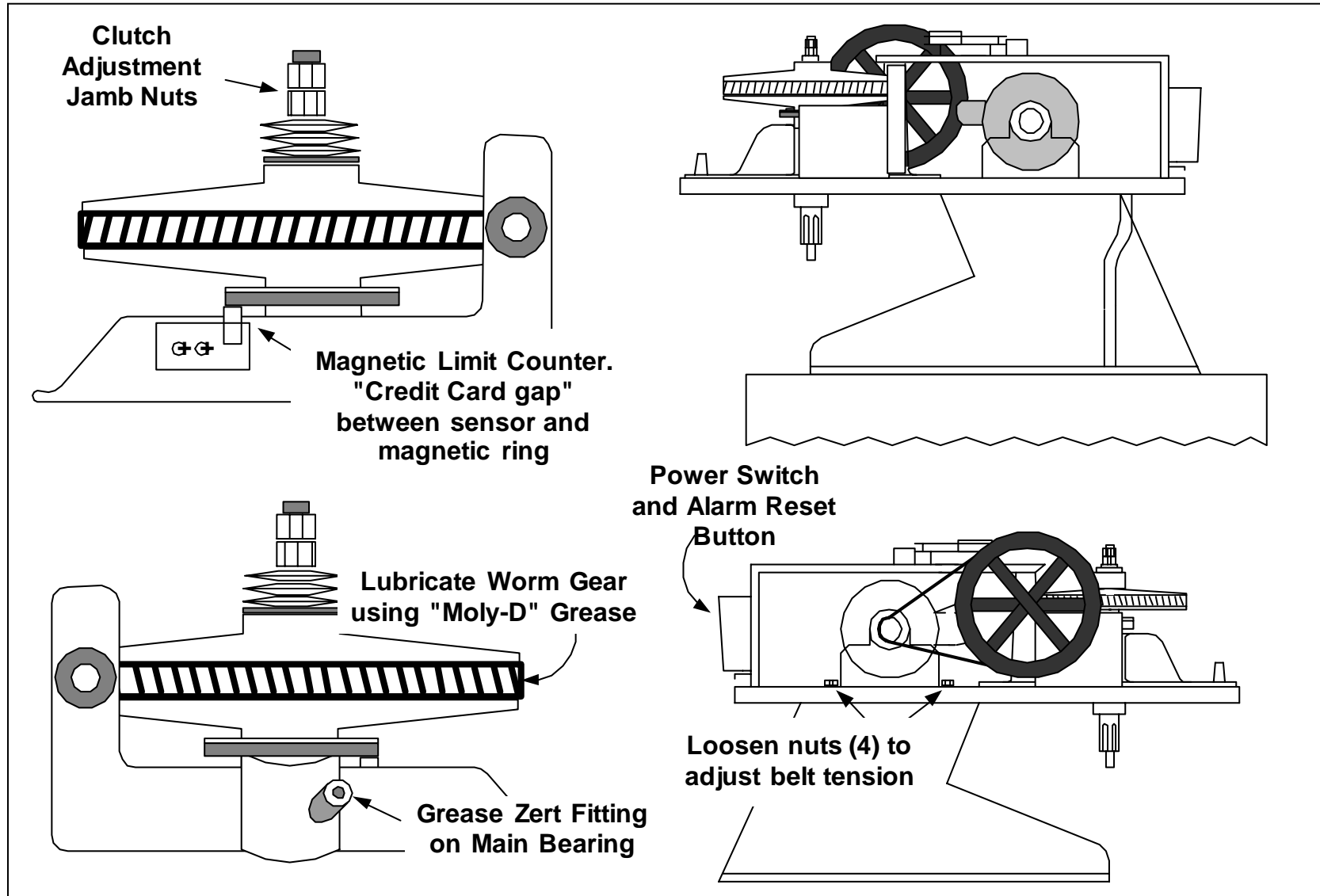

# TROUBLESHOOTING - DOORKING SWING GATE OPERATORS

## TESTING LOOP DETECTION SYSTEMS

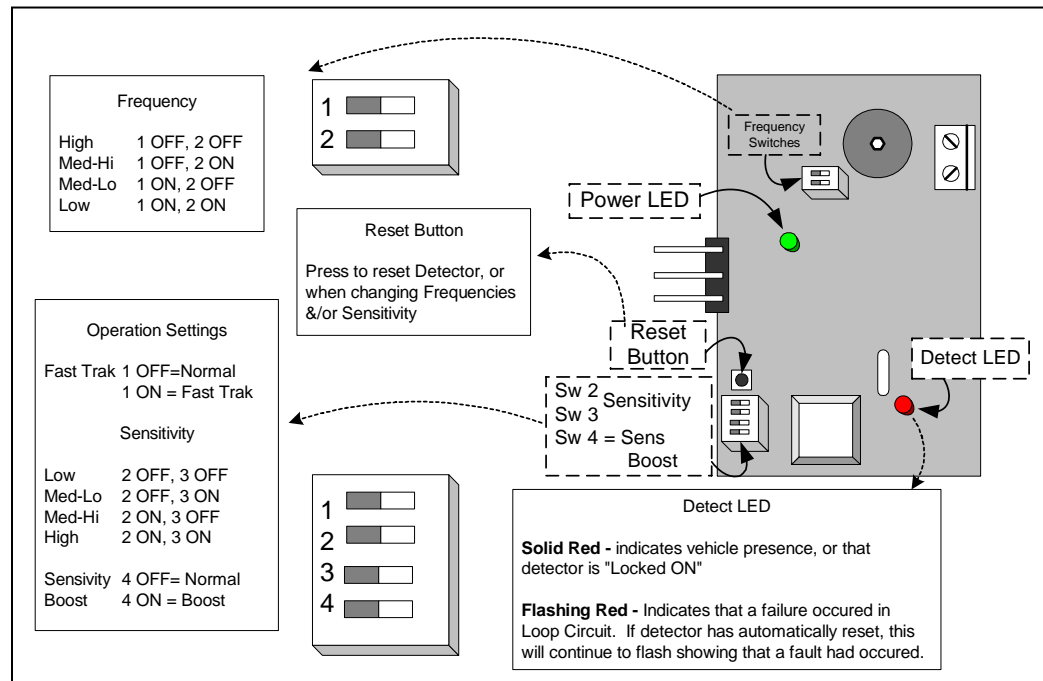

### Detector Adjustments:

**Frequency:** Separate each loop to avoid CrossTalk

**Sensitivity:** How much change is needed in Loop Field to detect. Can affect height of detection.

**Boost:** automatically boosts to an extremely high sensitivity upon detection. When vehicle leaves loop, sensitivity drops back to original setting.

**Fast Trak: USE WITH CAUTION!** This will help detector adjust as loop tuning drifts. *This also will lower Hold Time if a car parks over the loop*

**LED:** Red for Detect. Flash count on start-up to show frequency. Continuous blink indicates Loop Fault occurred. Will continue till reset.

# TROUBLESHOOTING - DOOR KING SWING GATE OPERATORS

## 3.4 ENTRAPMENT SENSING SYSTEM

This vehicular gate operator is equipped with an inherent adjustable clutch (Type C) that is used as the primary entrapment sensing system. The clutch will slip upon sensing an obstruction in either the opening or closing gate cycle and will cause the gate operator to reverse direction should an obstruction be encountered. For this system to function correctly, the gate must be properly installed and work freely in both directions. A good set of roller bearing hinges is essential for proper swing gate operation.

### 3.4.1 CLUTCH ADJUSTMENT

1. Be sure power to the operator is turned OFF whenever adjustments to the clutch are being made. Loosen the upper jamb nut to "un-lock" the lower jamb nut then loosen the lower jamb nut. (See figure 36 on the preceding page)
2. Manually move the gate so that it is positioned approximately half way open.
3. Tighten the lower jamb nut so that it is finger tight then tighten it one turn with a wrench. Re-tighten the upper jamb nut.
4. Apply power to the gate operator and momentarily short across terminals 11 and 20 with a 1-foot piece of 18 AWG wire. When the gate begins to open, determine if the clutch is slipping. If the clutch is slipping, turn power OFF and tighten the lower jamb nut one more turn. This process may have to be repeated several times to get the right clutch adjustment. Always start the gate from the half open position when adjusting the clutch.
5. After adjusting the clutch so that the gate opens and closes without it slipping, obstruct the gate while it is in the opening cycle. The clutch should slip with no more than 40 Lbs of force for approximately 2 seconds, and then the operator should reverse the direction of travel of the gate. If the clutch does not slip, it is too tight. Repeat step 4 and re-adjust the clutch. NOTE: After the gate has reversed, the operator will be in a "soft shutdown" making it necessary to initiate the cycle again by momentarily shorting across terminals 11 and 20.
6. Repeat step 5, only this time obstruct the gate while it is in the closing cycle. The clutch should slip with no more than 40 Lbs of force for approximately 2 seconds, and then the operator should reverse the direction of travel of the gate. If the clutch does not slip, it is too tight. Repeat step 4 and re-adjust the clutch. NOTE: After the gate has reversed, the operator will be in a "soft shutdown" making it necessary to initiate the cycle again by momentarily shorting across terminals 11 and 20.
7. The ideal clutch adjustment will allow the operator to move the gate through its entire travel cycle without slipping, but will slip upon contact with an obstruction with no more than 40 Lbs of force. This force can be measured with a gate scale, DoorKing P/N 2600-225.

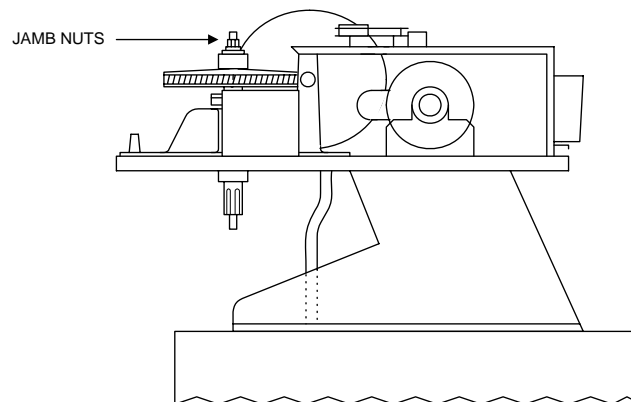

# DOORING SWING GATE OPERATORS

## Typical Block Wiring Diagram

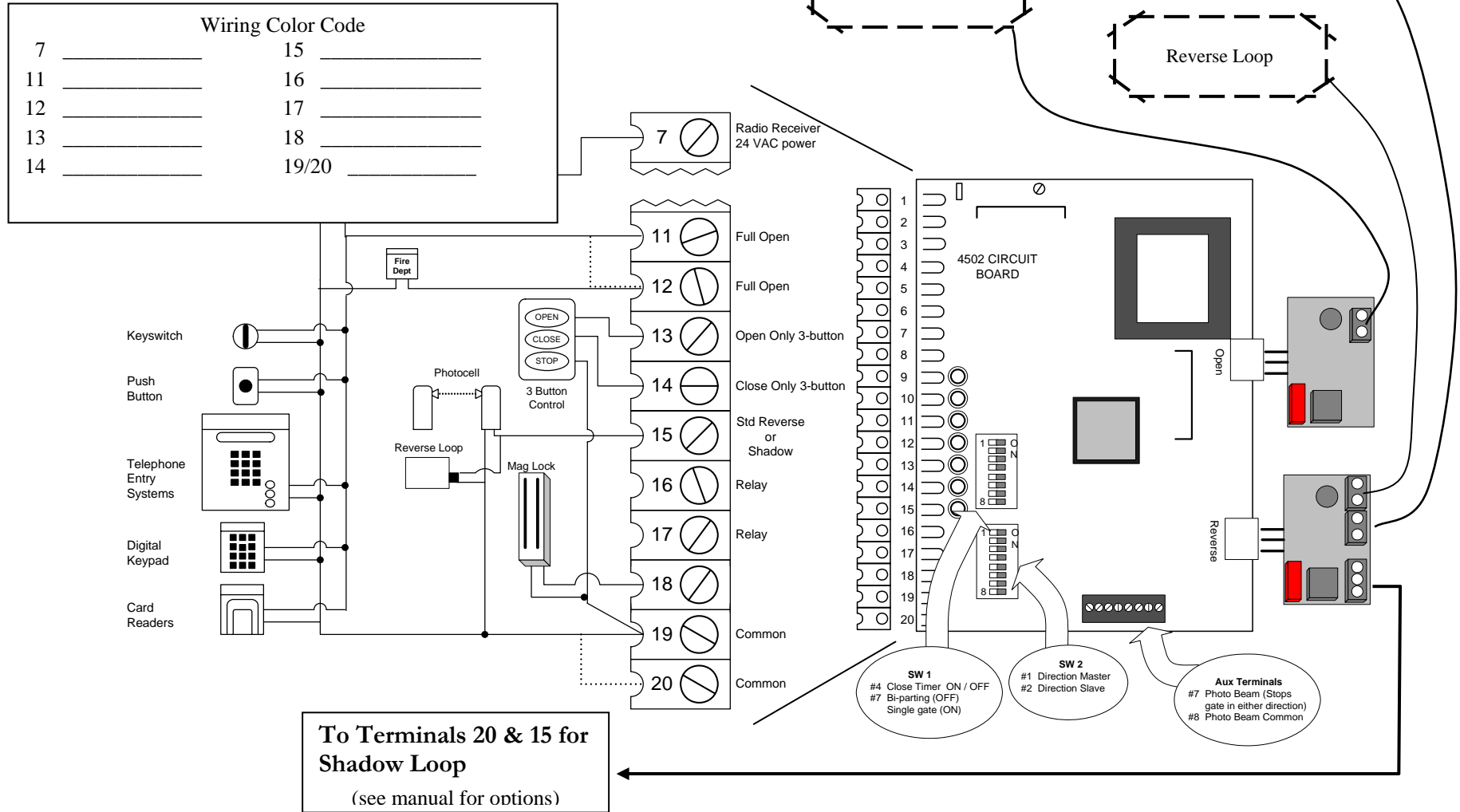

# DOORING SWING GATE OPERATORS

## LED Indicator Lights

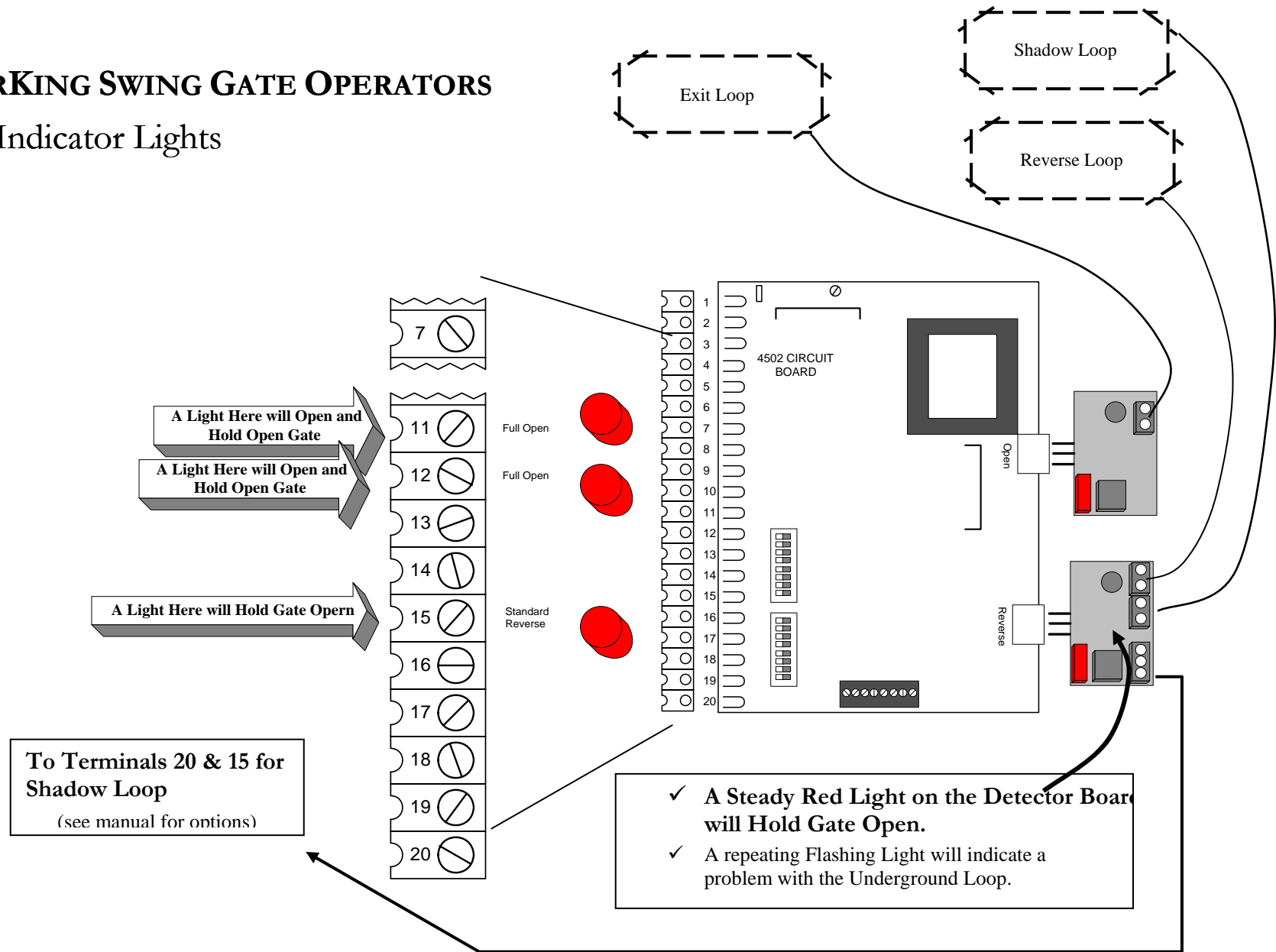

# TROUBLE SHOOTING - DOOR KING BARRIER ARM OPERATORS

---

**Model 1601 - Single Arm: 14' wooden Arm, 14' Aluminum Arm, 10' Plastic Arm**

**Model 1602 - Wishbone Arm: 20 Wooden 3-piece Arm**

- **Electronic Limit Settings** (no mechanical limit switches required).
- **ERD** - Reversing mechanism senses obstruction while arm is closing.
- **Automatic Close Timer** (1 – 23 seconds) can be used either separately or in conjunction with DOWN Loop.
- **Plug-in Loop Detectors** – ports for UP loop and for DOWN or Reverse loop.
- **Gate Arm Speed Controls** - The 1602 utilizes a specially geared drive mechanism to provide smooth gate movement even with the heavy 3-piece arm. The Arm opens in approx. 5 seconds. Closing and reversing actions are delayed to eliminate harmful whipping action in the arm movement.
- **Gate Tracker** - Service and Operational information can be transmitted, through a Tracker Board, to the Transaction buffer of a DoorKing PC Programmable system. This can also provide a dry relay contact when the gate encounters an obstruction.
- **Optional Battery Back-up drive** - upon loss of primary power gate can open automatically or on command.
- **Optional Heater and Fan kit** for extreme environments.
- **Reinforced Operator Cabinet** - The operator housing has been enlarged and reinforced to provide a more stable platform for the gate operation. In addition, the mounting of the gearbox and motor assembly has been reinforced.



# TROUBLE SHOOTING - DOOR KING BARRIER ARM OPERATORS

The switch settings and adjustments in this chapter should be made after your installation and wiring to the operator(s) is complete. Whenever any of the programming switches on the circuit board are changed, power must be shut-off, and then turned back on for the new setting to take effect.

## 3.1 CIRCUIT BOARD ADJUSTMENTS

- Set the DIP-switches on the circuit board to the desired setting. See switch-setting charts in section 3.2.
- Auto close timer (when turned on) can be set from 1 second (full counter clockwise) to approximately 23 seconds (full clockwise).
- Rotate the ERD potentiometer clockwise to increase sensitivity, counter clockwise to decrease sensitivity.
- Dry contact relay contacts (terminals 12-13) can be set for Normally Open (NO) or Normally Closed (NC) operation by placing the relay shorting bar on the NO or NC pins respectively.
- Power LED indicates that low voltage power is applied to the circuit board. The input LEDs should be OFF and will only illuminate when the input is activated.
- Limit LEDs will be ON when the arm is in the respective position.
- Tracker and COMM LEDs indicate data communication to the Tracker board.

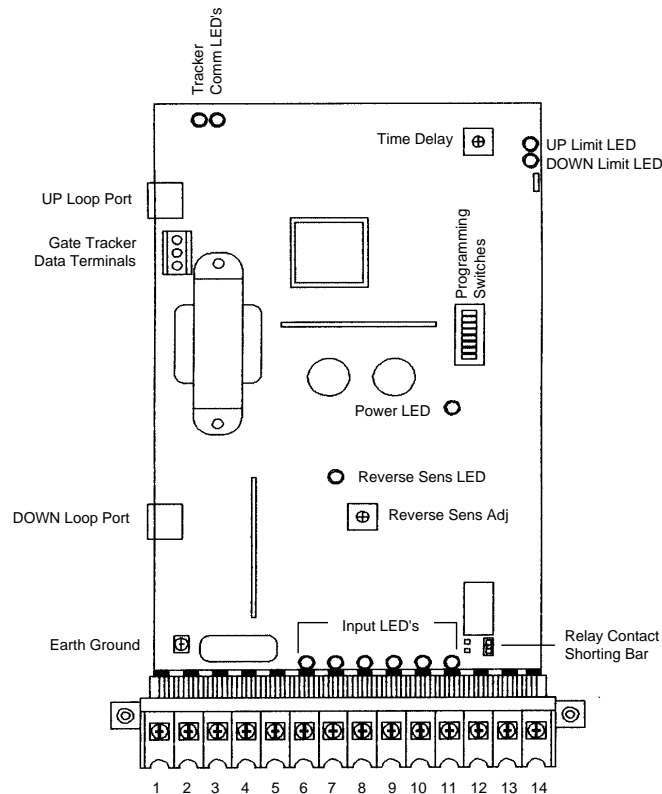

Figure 6



# TROUBLE SHOOTING - DOOR KING BARRIER ARM OPERATORS

## 3.4 REVERSE SENSITIVITY ADJUSTMENT

The barrier gate operator is equipped with an Electronic Reversing Device (ERD) which will cause the barrier arm to reverse direction of travel should an object be encountered during the down cycle. The amount of force required for the arm to reverse direction is dependent on the setting of the reverse sensitivity potentiometer. The ERD has no effect on the arm travel should an object be encountered by the arm in the up direction. Follow the instructions below to adjust the ERD potentiometer.

The ERD will have to be adjusted after the arm has been installed on the barrier operator. Do not adjust the ERD until after the arm has been installed per section 4.1.

1. Turn the AC power toggle switch to the ON position.
2. Place the control toggle switch to the UP position. The arm should rotate UP.
3. Momentarily press the control toggle switch to the DOWN position. This will cause the arm to rotate down. **CAUTION:** Be sure that all persons and vehicles are clear of the arm before pressing the down toggle switch!
4. While the arm is traveling in the down direction, rotate the reverse potentiometer clockwise until the reverse LED illuminates. The arm will reverse travel at this time.
5. Rotate the reverse potentiometer 1/8 turn counter clockwise.
6. You may have to repeat the adjustment a few times to find a satisfactory setting.

The ERD in the barrier operator is not intended to replace external reversing devices such as loops, photo electric eyes, or reversing edges. It is important that these devices be installed according to the needs and requirements of your particular application.

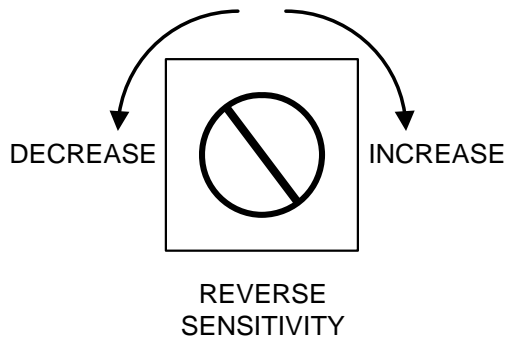

Figure 7

# TROUBLE SHOOTING - DOOR KING BARRIER ARM OPERATORS

## MAINTENANCE

MONTHLY SCHEDULE		INTERVAL		
		3	6	12
Arm	Check for cracks or weathering. Repair or replace as necessary.		✓	
Belt	Check for alignment, tightness and wear.		✓	
ERD	Check the electronic reversing device for proper operation. Adjust sensitivity if necessary.	✓		
Fire Dept.	Check emergency vehicle access device(s) for proper operation.	✓		
Gearbox	Check oil level.			✓
Linkages	Check internal linkages for wear. Inspect bushing for wear.		✓	
Loops	Check all external ground loops for proper operation.	✓		
Pulleys	Check set-screws for tightness.		✓	
Reversing Devices	Check electric edges and photo-cells for proper operation.	✓		
Complete Check	Perform a complete system check. Include all reversing devices, loops, access system devices, Fire Dept. access devices, etc.			✓

- When servicing, place AC power switch to the OFF position. If the operator is equipped with a battery back-up system, place the battery power switch to the OFF position.
- Inspection and service should be performed anytime a malfunction is observed or suspected. High cycle usage may require more frequent service checks.
- **Use only Shell OMALA 150 gear oil when adding or replacing gearbox oil. IMPORTANT: Do not fill gearbox to top. Gearbox is full when oil completely covers inspection window.**

Always check external reversing devices (loops, photo-cells, etc.) when performing maintenance. **If reversing devices are not functional and cannot be placed in an operable state, DO NOT PLACE OPERATOR IN SERVICE.** If the operator is equipped with a battery back-up system, follow the steps below to check the operation of this system.

**CAUTION: Keep clear of the arm and all internal moving parts.**

1. Prior to checking the battery back-up system, both the AC power switch and the battery back-up switch should be in the ON position.
2. Place the AC power switch to the OFF position. The arm should rotate to the UP position approximately two seconds after the AC power switch is shut off.
3. Turn the AC power switch to the ON position. The operator will resume normal operation.

# TROUBLE SHOOTING - DOOR KING BARRIER ARM OPERATORS

<u>Symptom</u>	<u>Items to check</u>
Operator will not run	<ol style="list-style-type: none"><li>1. Be sure AC power switch is on.</li><li>2. Check if Power LED on circuit board is on.</li></ol>
Operator will not run Power LED is ON	<ol style="list-style-type: none"><li>1. Activate Card Reader, Transmitter or Phone Entry. Look at circuit board inside Gate Operator and see if red LED on terminals 6 or 7 light up when device is activated.</li><li>2. Toggle the manual UP / DOWN switch. Gate should move up then down.</li></ol>
Gate opens but will not close.	<ol style="list-style-type: none"><li>1. Check if circuit board LED on terminals 6, 7, 9 are on. If so, some device may be holding gate open.</li><li>2. Check red LED on Reverse and Exit Loop Detectors. If on then loop is holding gate open.</li><li>3. If auto close timer is not used, check bank of dip switches. Switch #7, close timer, should be OFF, Switch #6, up input: OFF= up command only, ON= key open, key close. Switch #4, Down Loop, ON= close gate with loop.</li></ol>
Gate starts to close then reverses to open.	<ol style="list-style-type: none"><li>1. Check ERD LED. If it flashes when gate is closing then rotate the ERD sensitivity potentiometer counter clockwise 1/8 of a turn.</li><li>2. Check Loop Detector LED's to see if loop is reversing the gate.</li></ol>
Down input / down loop will not close gate.	<ol style="list-style-type: none"><li>1. Check that switch #4 is in the ON position.</li><li>2. Down input must be activated then de-activated to close gate.</li></ol>
Loop Detector LED is on continuously.	<ol style="list-style-type: none"><li>1. Activate reset switch on loop detector (for DoorKing Model 9405, 9406 detectors this is a small push button next to the large bank of dip switches. To reset press reset button.</li></ol>

## **TROUBLE SHOOTING HINTS**

If a malfunction occurs, isolate the problem to one of three areas: The Operator, The Keying Devices (card reader, phone entry, etc.) or the Loop Detectors.

When placing a service call to the Authorized Dealer, relate what you found when following the above steps.

# DOORKING BARRIER ARM OPERATORS

## Quick Start Wiring

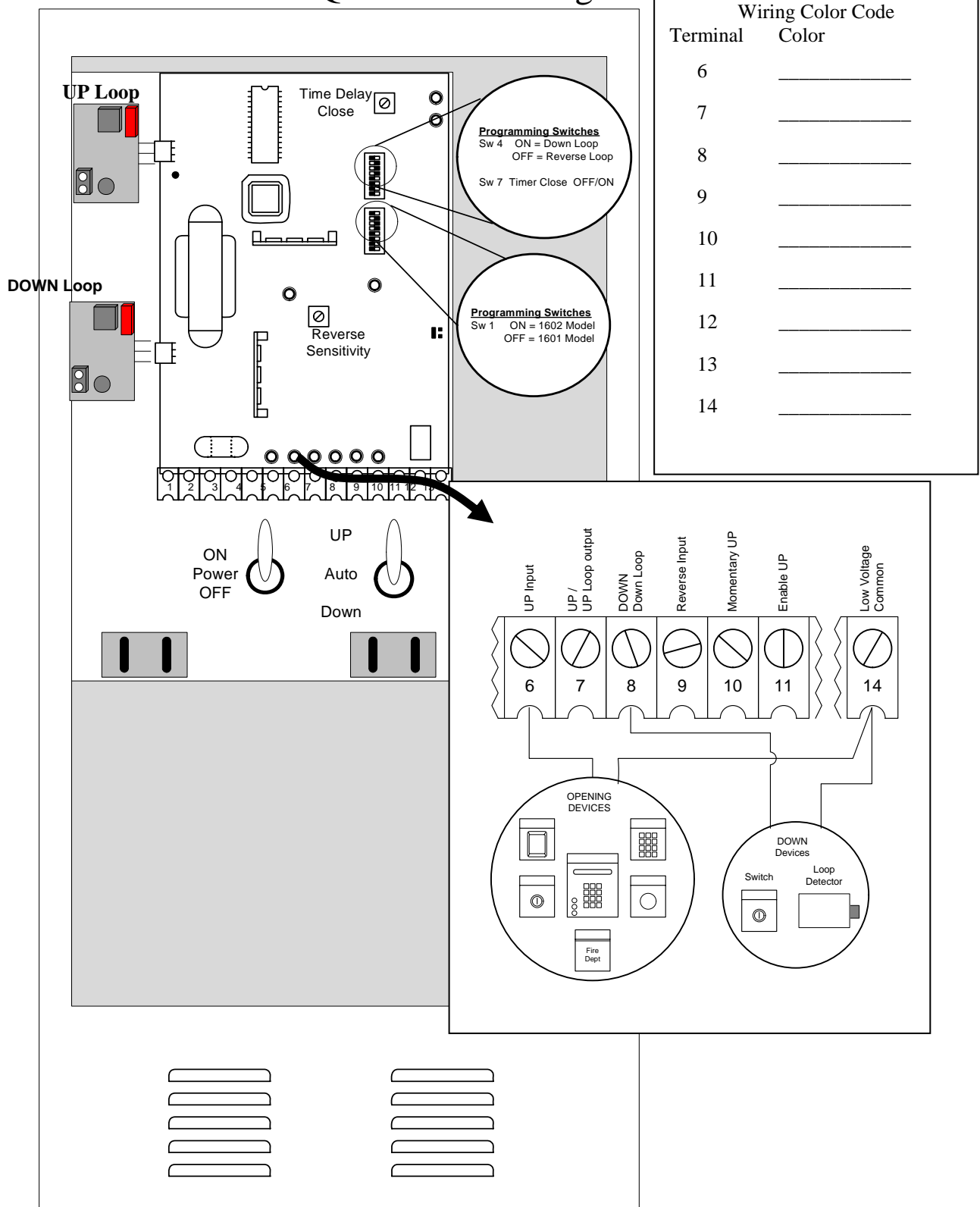

Wiring Color Code	
Terminal	Color
6	_____
7	_____
8	_____
9	_____
10	_____
11	_____
12	_____
13	_____
14	_____

**Programming Switches**  
 Sw 4 ON = Down Loop  
 OFF = Reverse Loop  
 Sw 7 Timer Close OFF/ON

**Programming Switches**  
 Sw 1 ON = 1602 Model  
 OFF = 1601 Model

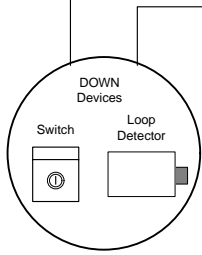
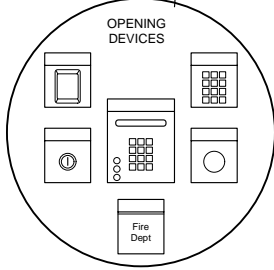
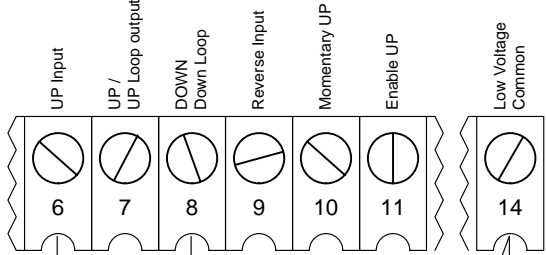

# DOORKING PARKING GATE OPERATORS

## LED Indicator Lights

